

Manual

D120 Draw wire system



Publisher	Kübler Group, Fritz Kübler GmbH Schubertstr. 47 78054 Villingen-Schwenningen Germany www.kuebler.com
Application support	Phone +49 7720 3903 -952 Fax +49 7720 21564 support@kuebler.com
Document no.	R67044.0002
Document title	Manual, D120 Draw wire system
Language version	English (EN) - German is the original version
Document version	04.08.2017, R67044.0002 - Index 1
Copyright	© 2017, Kübler Group, Fritz Kübler GmbH
Legal information	All of the contents of this device description are subject to the rights of use and copyrights of Fritz Kübler GmbH. Any duplication, modification, further use or publication in other electronic or printed media, as well as their publication in the Internet, is subject to the previous written authorization of Fritz Kübler GmbH.

Table of Contents

Table of Contents

1. Mounting4

1. Mounting

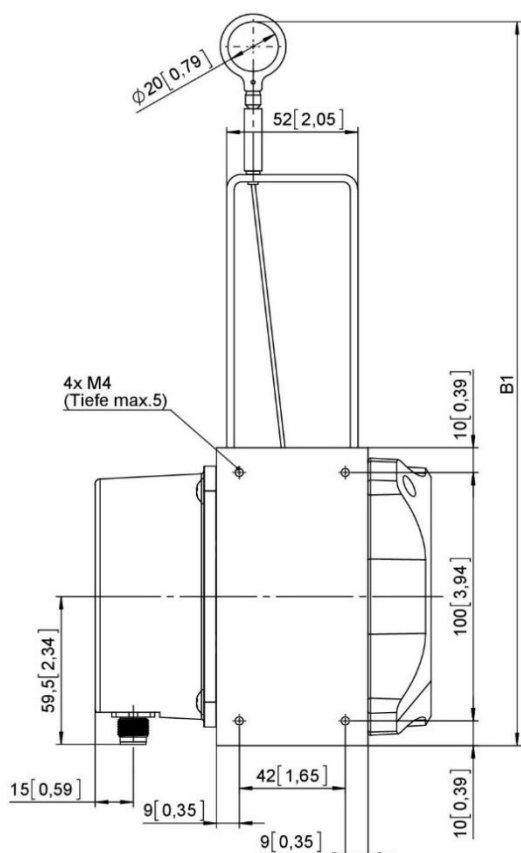

Fasten the sensor at the place provided to that purpose using the fastening holes before pulling the wire out or fastening the wire on the object to be measured.

The sensor can be mounted with 4 M4 threaded holes (max. depth 5 mm).

These threaded holes are available on 2 sides of the housing to allow 2 different mounting positions.

Caution:

The perforated plate of variants CX11, CX1X and CXX1 is not suitable for fastening the sensor.

Once the sensor is mounted, the wire can be pulled with caution out of the sensor and fastened on the object to be measured.

Caution:

In no case let the wire go while pulling it out and make sure that it is neither bent nor kinked while fastening it.

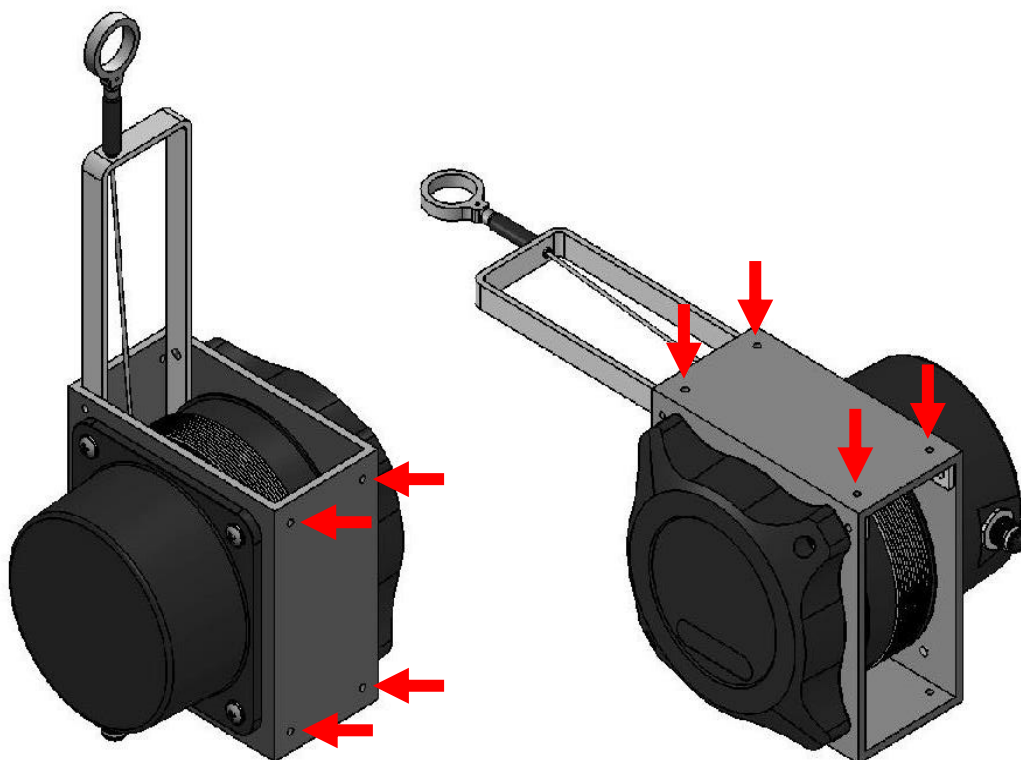



Kübler Group
Fritz Kübler GmbH
Schubertstr. 47
78054 Villingen-Schwenningen
Germany
Phone +49 7720 3903-0
Fax +49 7720 21564
info@kuebler.com
www.kuebler.com